

SPECIFICATIONS FOR NICHIA CHIP TYPE **WHITE** LED

MODEL : **NCCW022S**

NICHIA CORPORATION

1.SPECIFICATIONS

(1) Absolute Maximum Ratings (Tc=25°C)

Item	Symbol	Absolute Maximum Rating	Unit
Forward Current	I _F	500	mA
Pulse Forward Current	I _{FP}	1000	mA
Allowable Reverse Current	I _R	85	mA
Power Dissipation	P _D	2.0	W
Operating Temperature	T _{opr}	-30 ~ + 85	°C
Storage Temperature	T _{stg}	-40 ~ +100	°C
Dice Temperature	T _j	105	°C

I_{FP} Conditions : Pulse Width ≦ 10msec. and Duty ≦ 1/10

(2) Initial Electrical/Optical Characteristics (Tc=25°C)

Item	Symbol	Condition	Min.	Typ.	Max.	Unit
Forward Voltage	Rank M	I _F =350[mA]	3.6	-	4.0	V
	Rank L		3.2	-	3.6	
Luminous Flux	Rank P13	I _F =350[mA]	42.8	-	51.0	lm
	Rank P12		36.0	-	42.8	
	Rank P11		30.3	-	36.0	

* Forward Voltage Measurement allowance is ± 3%.

* Luminous Flux Measurement allowance is ± 7%.

* T_c : The case temperature of products (Please refer to the drawing, 050509539291.)

Color Ranks

(I_F=350mA, T_c=25°C)

	Rank b3			
x	0.287	0.283	0.304	0.307
y	0.295	0.305	0.330	0.315

	Rank b4			
x	0.307	0.304	0.330	0.330
y	0.315	0.330	0.360	0.339

	Rank b5			
x	0.296	0.287	0.307	0.311
y	0.276	0.295	0.315	0.294

	Rank b6			
x	0.311	0.307	0.330	0.330
y	0.294	0.315	0.339	0.318

	Rank c1			
x	0.330	0.330	0.361	0.357
y	0.339	0.360	0.385	0.361

	Rank c2			
x	0.330	0.330	0.357	0.356
y	0.318	0.339	0.361	0.351

* Color Coordinates Measurement allowance is ± 0.01.

2.TYPICAL INITIAL OPTICAL/ELECTRICAL CHARACTERISTICS

Please refer to figure's page.

3.OUTLINE DIMENSIONS AND MATERIALS

Please refer to figure's page.

Material as follows ;	Package	:	Heat-Resistant Polymer
	Encapsulating Resin	:	Silicone Resin (with Phosphor)
	Electrodes	:	Ag Plating Copper Alloy
	Lens	:	Silicone Resin (with Diffused)

4.PACKAGING

- The LEDs are packed in cardboard boxes after packaging in stick.

Please refer to figure's page.

The label on the minimum packing unit shows ; Part Number, Lot Number, Ranking, Quantity

- In order to protect the LEDs from mechanical shock, we pack them in cardboard boxes for transportation.
- The LEDs may be damaged if the boxes are dropped or receive a strong impact against them, so precautions must be taken to prevent any damage.
- The boxes are not water resistant and therefore must be kept away from water and moisture.
- When the LEDs are transported, we recommend that you use the same packing method as Nichia.

5.LOT NUMBER

The first six digits number shows **lot number**.

The lot number is composed of the following characters;

○□×××× - △■●

- - Year (4 for 2004, 5 for 2005)
- - Month (1 for Jan., 9 for Sep., A for Oct., B for Nov.)
- ×××× - Nichia's Product Number
- △ - Ranking by Color Coordinates
- - Ranking by Luminous Flux
- - Ranking by Forward Voltage

6.RELIABILITY

(1) TEST ITEMS AND RESULTS

Test Item	Standard Test Method	Test Conditions	Note	Number of Damaged
Resistance to Soldering Heat (Reflow Soldering)		Tsld=260°C, 10sec. (Pre treatment 30°C,70%,12hrs.)	1 time	0/10
Solderability (Reflow Soldering)	JEITA ED-4701 300 303	Tsld=215 ± 5°C, 3sec. (Lead Solder)	1 time	0/10
Temperature Cycle	JEITA ED-4701 100 105	-40°C ~ 25°C ~ 100°C ~ 25°C 30min. 5min. 30min. 5min.	100 cycles	0/10
High Temperature Storage	JEITA ED-4701 200 201	Ta=100°C	1000 hrs.	0/10
Temperature Humidity Storage	JEITA ED-4701 100 103	Ta=60°C, RH=90%	1000 hrs.	0/10
Low Temperature Storage	JEITA ED-4701 200 202	Ta=-40°C	1000 hrs.	0/10
Steady State Operating Life		Ta=25°C, IF=500mA Tested with Nichia standard circuit board.*	1000 hrs.	0/10
Steady State Operating Life of High Temperature		Ta=85°C, IF=120mA Tested with Nichia standard circuit board.*	1000 hrs.	0/10
Steady State Operating Life of High Humidity Heat		60°C, RH=90%, IF=290mA Tested with Nichia standard circuit board.*	500 hrs.	0/10
Steady State Operating Life of Low Temperature		Ta=-30°C, IF=350mA Tested with Nichia standard circuit board.*	1000 hrs.	0/10
Vibration	JEITA ED-4701 400 403	200m/s ² , 100 ~ 2000Hz (Sweep 4min.) 48min., 3directions	4 times	0/10
Electrostatic Discharge	JEITA ED-4701 300 304	R=1.5kΩ, C=100pF Test Voltage=2kV	3 times Negative/Positive	0/10

* Thermal resistance of LED with Nichia standard circuit board : $R_{ja} \cong 39^{\circ}\text{C}/\text{W}$

(2) CRITERIA FOR JUDGING THE DAMAGE

Item	Symbol	Test Conditions	Criteria for Judgement	
			Min.	Max.
Forward Voltage	V _F	I _F =350mA	-	Initial Level × 1.1
Luminous Flux	φ _V	I _F =350mA	Initial Level × 0.7	-

* The test is done after the board is cooled down enough at the room temperature.

7.CAUTIONS

The LEDs are devices which are materialized by combining Blue LEDs and special phosphors. Consequently, the color of the LEDs is changed a little by an operating current. Care should be taken after due consideration when using LEDs. The chromaticity coordinate of the LEDs can shift approximately $x=0.02$, $y=0.03$ in the direction of blue 1000 hours later.

(1) Moisture Proof Package

- When moisture is absorbed into the SMT package it may vaporize and expand during soldering. There is a possibility that this can cause exfoliation of the contacts and damage the optical characteristics of the LEDs. For this reason, the moisture proof package is used to keep moisture to a minimum in the package.
- The moisture proof package is made of an aluminum moisture proof bag with a zipper. A package of a moisture absorbent material (silica gel) is inserted into the aluminium moisture proof bag. The silica gel changes its color from blue to pink as it absorbs moisture.

(2) Storage

· Storage Conditions

Before opening the package :

The LEDs should be kept at 30°C or less and 90%RH or less. The LEDs should be used within a year.

When storing the LEDs, moisture proof packaging with absorbent material (silica gel) is recommended.

After opening the package :

The LEDs should be kept at 30°C or less and 70%RH or less. The LEDs should be soldered within 12 hours after opening the package. If unused LEDs remain, they should be stored in the moisture proof packages, such as sealed containers with packages of moisture absorbent material (silica gel). It is also recommended to return the LEDs to the original moisture proof bag and to reseal the moisture proof bag again.

- In case of using remaining LEDs once opened from original packing and were not used, LEDs should be soldered after baking treatment according to the following profile.
- If the moisture absorbent material (silica gel) has faded away or the LEDs have exceeded the storage time, baking treatment should be performed using the following condition.
Baking treatment : more than 24 hours at 85°C, and 10%RH or less
- Nichia LED electrode , leadframe and Die Heat sink are comprised of a silver plated copper alloy. The silver surface may be affected by environments which contain corrosive gases and so on. Please avoid conditions which may cause the LED to corrode, tarnish or discolor. This corrosion or discoloration might lower solderability or might affect on optical characteristics.
- Please avoid rapid transitions in ambient temperature, especially in high humidity environments where condensation can occur.
- When the LEDs are moved from hot and humid ambience to cold ambience, the insides of lenses are fogged up, but it is dissolved by leaving.

(3) Static Electricity

- Static electricity or surge voltage damages the LEDs.
It is recommended that a wrist band or an anti-electrostatic glove be used when handling the LEDs.
- All devices, equipment and machinery must be properly grounded.
It is recommended that measures be taken against surge voltage to the equipment that mounts the LEDs.
- When inspecting the final products in which LEDs were assembled, it is recommended to check whether the assembled LEDs are damaged by static electricity or not. It is easy to find static-damaged LEDs by a light-on test or a VF test at a lower current (below 1mA is recommended).
- Damaged LEDs will show some unusual characteristics such as the forward voltage becomes lower, or the LEDs do not light at the low current. Criteria : ($V_F > 2.0V$ at $I_F=0.5mA$)

(4) Soldering Conditions

· The LEDs can be soldered in place using the reflow soldering method. Nichia cannot make a guarantee on the LEDs after they have been assembled using the dip soldering method.

· Recommended soldering conditions

	Reflow Soldering		Hand Soldering (Lead part)	
	Lead Solder	Lead-free Solder	Temperature	Soldering time
Pre-heat	120 ~ 150°C	180 ~ 200°C	350°C Max. 3 sec. Max. (one time only)	
Pre-heat time	120 sec. Max.	120 sec. Max.		
Peak temperature	240°C Max.	260°C Max.		
Soldering time	10 sec. Max.	10 sec. Max.		
Condition	refer to Temperature - profile ①.	refer to Temperature - profile ②. (N ₂ reflow is recommended.)		

* After reflow soldering rapid cooling should be avoided.

[Temperature-profile (Surface of circuit board)]

<① : Lead Solder>

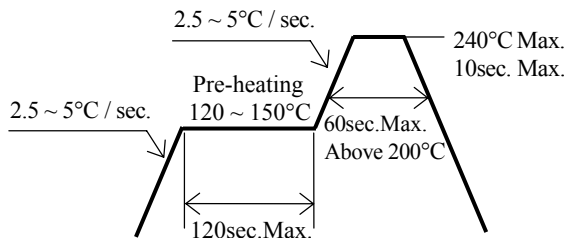

Use the conditions shown to the under figure.

<② : Lead-free Solder>

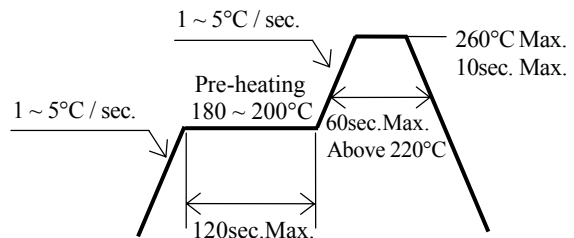

[Recommended soldering pad design]

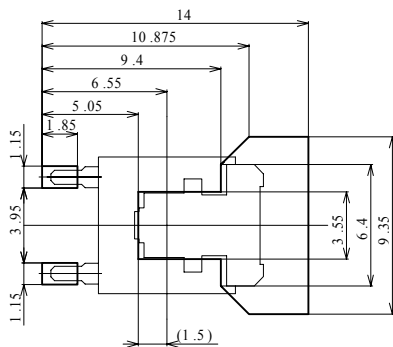

Use the following conditions shown in the figure.

(Unit : mm)

- Occasionally there is a brightness decrease caused by the influence of heat or ambient atmosphere during air reflow. It is recommended that the User use the nitrogen reflow method.
- Repairing should not be done after the LEDs have been soldered. When repairing is unavoidable, a hot plate should be used. It should be confirmed beforehand whether the characteristics of the LEDs will or will not be damaged by repairing.
- Reflow soldering should not be done more than one time.
- Die Heat sink is to be soldered. If not, please use the heat conductive adhesive.
- When soldering, do not put stress on the LEDs during heating.
- After soldering, do not warp the circuit board.

(5) Heat Generation

- Thermal design of the end product is of paramount importance. Please consider the heat generation of the LED when making the system design. The coefficient of temperature increase per input electric power is affected by the thermal resistance of the circuit board and density of LED placement on the board, as well as other components. It is necessary to avoid intense heat generation and operate within the maximum ratings given in this specification.
- Please decide on operating current volume according to LEDs' ambient temperature and conduct heat release treatment.
- The equation ① indicates correlation between T_j and T_a , and the equation ② indicates correlation between T_j and T_c .

$$T_j = T_a + R_{ja} \cdot W \quad \text{..... ①} \qquad T_j = T_c + R_{jc} \cdot W \quad \text{..... ②}$$

* T_j = Dice Temperature : °C, T_a = Ambient Temperature : °C, T_c = Case Temperature : °C

R_{ja} = Heat resistance from Dice to Ambient temperature : °C /W,

R_{jc} = Heat resistance from Dice to T_c measuring point \cong 17°C /W,

W = Inputting Power ($I_F \times V_F$) : W

(6) Others

- Encapsulating resin is made from silicone. Silicone has clambered up the lens thinly, so there is possibility of occurring delamination on the surface of the lens. Please take care of handling for LEDs.
- The LED light output is strong enough to injure human eyes. Precautions must be taken to prevent looking directly at the LEDs with unaided eyes for more than a few seconds.
- Flashing lights have been known to cause discomfort in people; you can prevent this by taking precautions during use. Also, people should be cautious when using equipment that has had LEDs incorporated into it.
- The LEDs described in this brochure are intended to be used for ordinary electronic equipment (such as office equipment, communications equipment, measurement instruments and household appliances). Consult Nichia's sales staff in advance for information on the applications in which exceptional quality and reliability are required, particularly when the failure or malfunction of the LEDs may directly jeopardize life or health (such as for airplanes, aerospace, submersible repeaters, nuclear reactor control systems, automobiles, traffic control equipment, life support systems and safety devices).
- User shall not reverse engineer by disassembling or analysis of the LEDs without having prior written consent from Nichia. When defective LEDs are found, the User shall inform Nichia directly before disassembling or analysis.
- The formal specifications must be exchanged and signed by both parties before large volume purchase begins.
- The appearance and specifications of the product may be modified for improvement without notice.

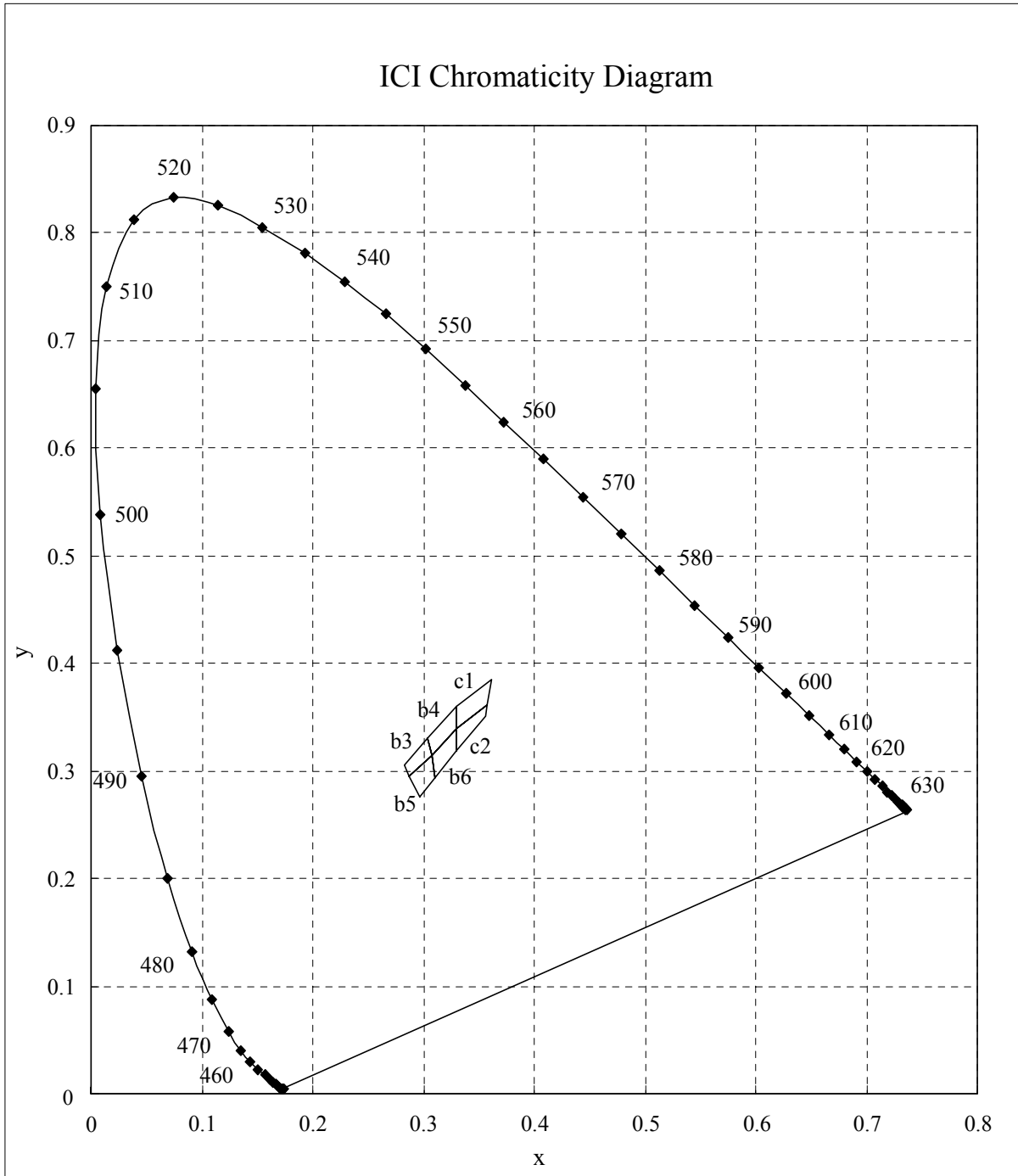

* Color Coordinates Measurement allowance is ± 0.01 .

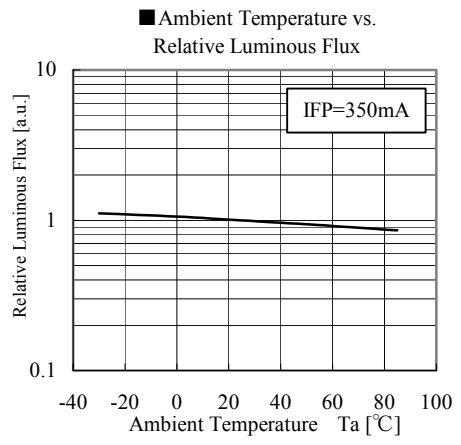
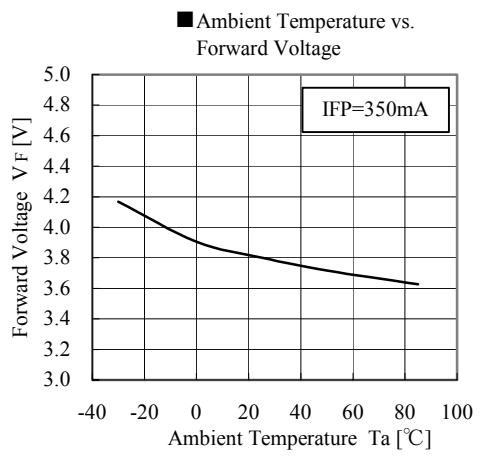
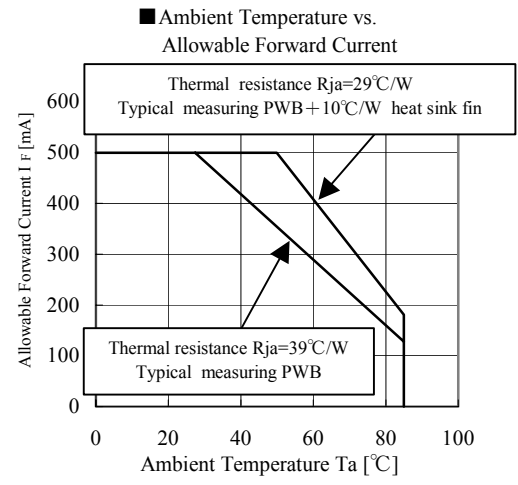
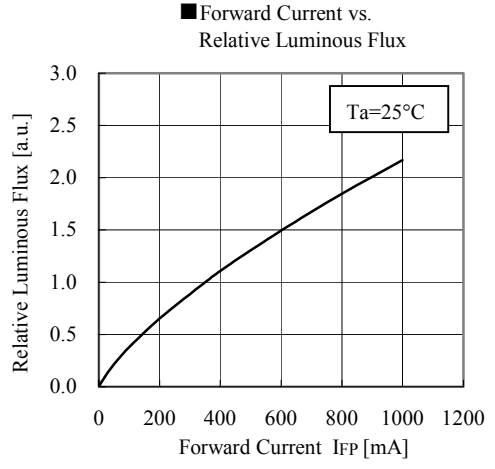
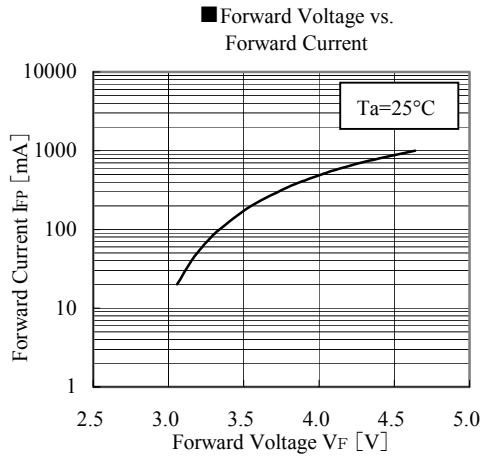

NICHIA CORPORATION	Model	NCCW02x
	Title	TYP. CHARACTERISTICS
	No.	040407400811

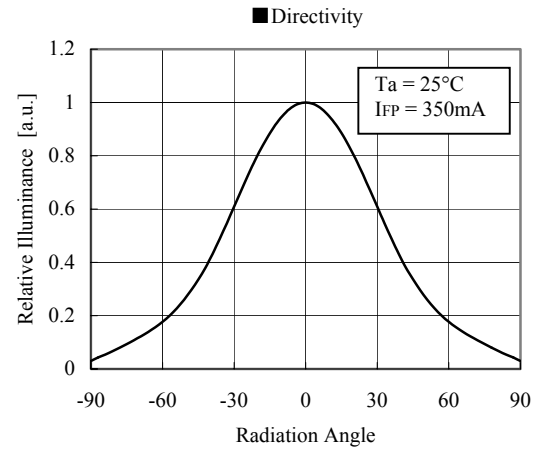
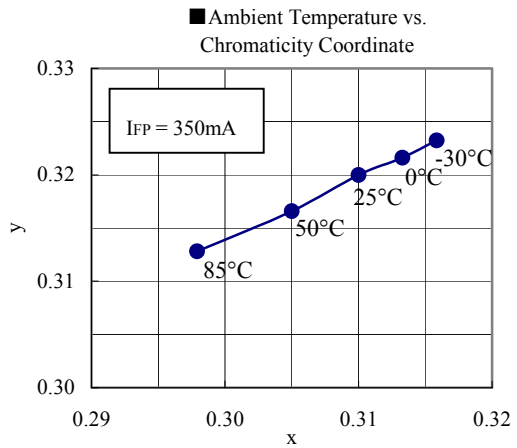
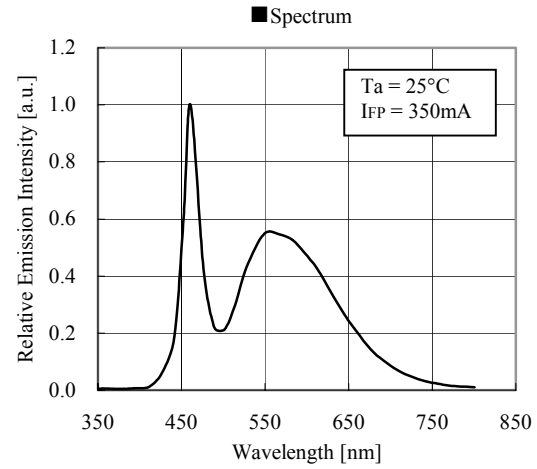
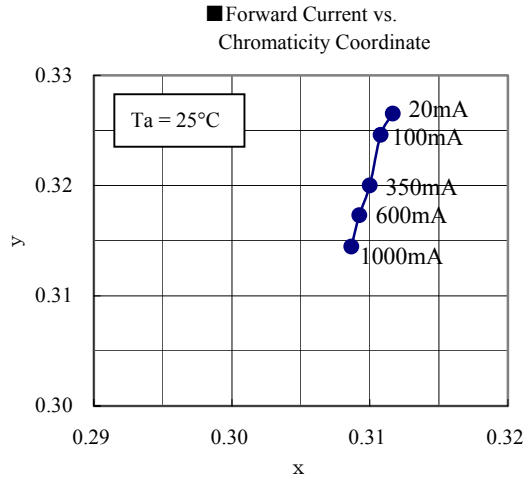

NICHIA CORPORATION	Model	NCCW022
	Title	TYP. CHARACTERISTICS
	No.	041215400822

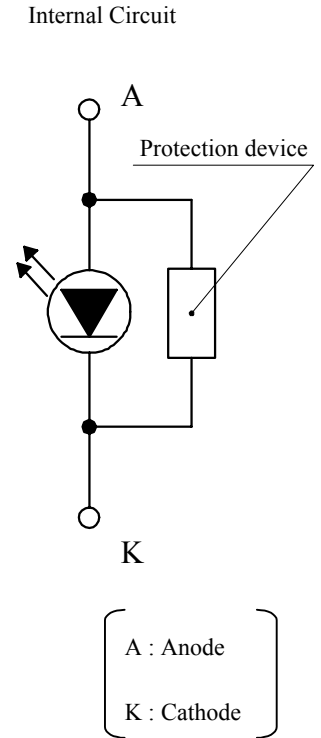
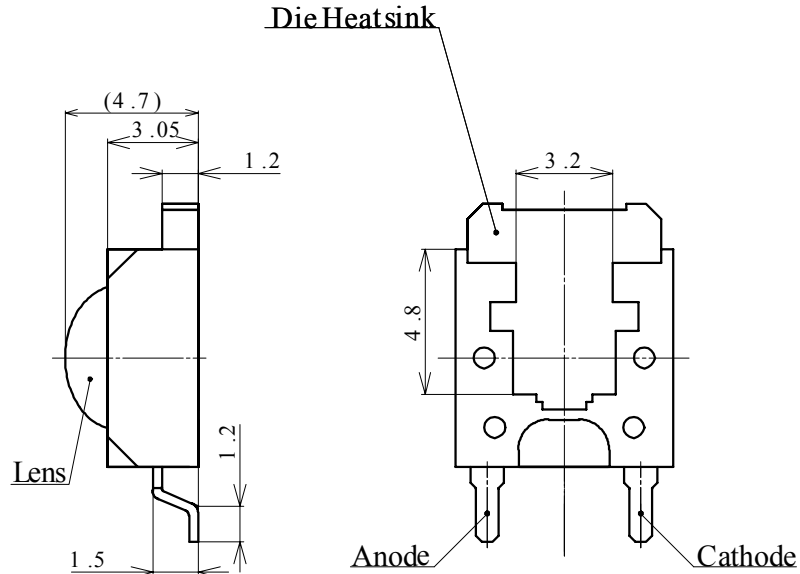
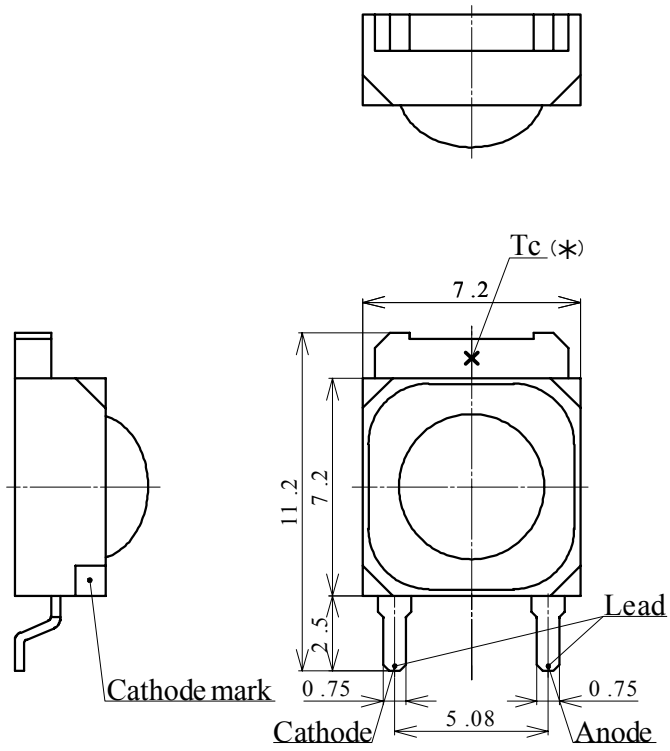

* Tc : Measure point of case temperature

ITEM	MATERIALS
Package	Heat-Resistant Polymer
Encapsulating Resin	Silicone Resin (with Phosphor)
Electrodes	Ag Plating Copper Alloy
Lens	Silicone Resin (with Diffused)

NICHIA CORPORATION	Model	NCCW022	Unit mm 4/1 Scale
	Title	OUTLINE DIMENSIONS	
	No.	050509539291	Allow ±0.2

Whole image of stick

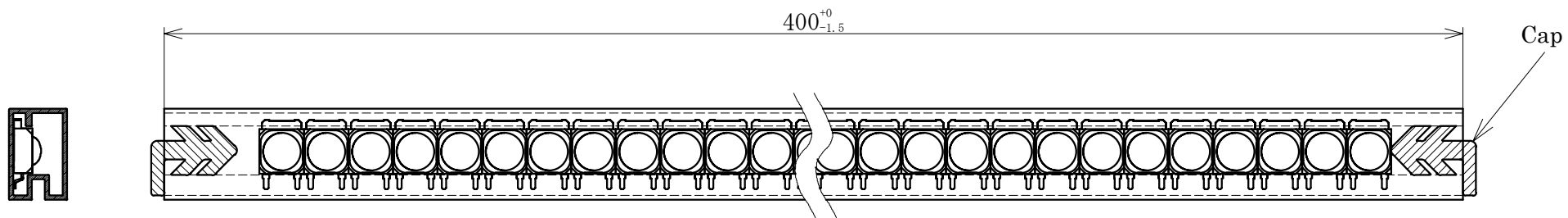

*1 50pcs (Max.)/stick

*2 10 Sticks can be banded at most

Cross sectional image of stick

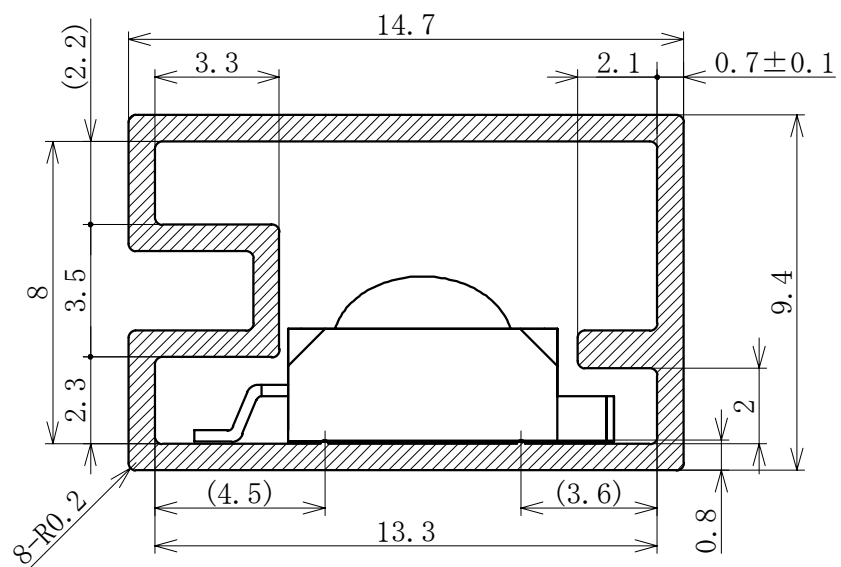

NICHIA CORPORATION	Model	NCCx022S	Unit mm
	Title	STICK DIMENSIONS	
	No.	050111536491	Scale Allow ±0.2

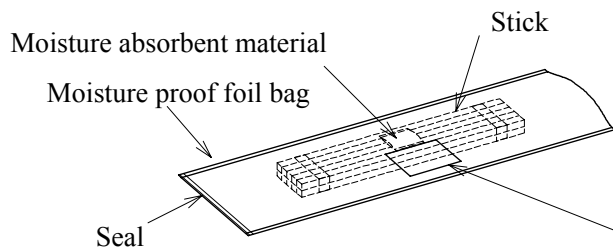

Label

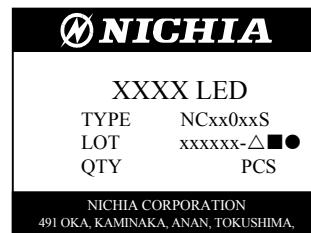

The stick and moisture absorbent material are put in the moisture proof foil bag and then heat sealed.



Empty space in the box is filled with cushion material.

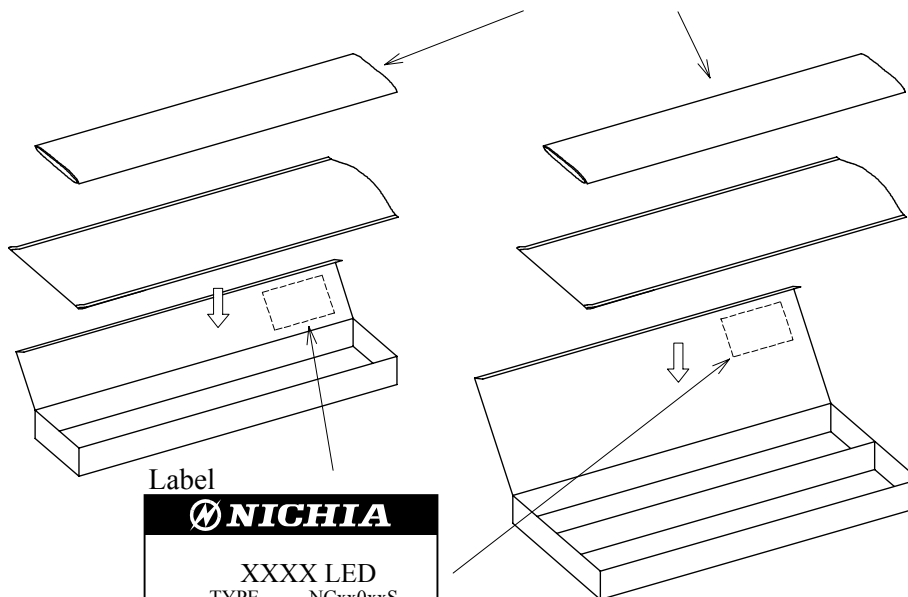

Label



Packing unit

	Stick/Bag	Quantity/Bag (pcs)
Moisture proof foil bag	10pcs MAX.	500 MAX.

Cardboard box	Dimensions (mm)	Stick/Box	Quantity/Box (pcs)
Cardboard box S	580×124×66×3t	30pcs MAX.	1,500 MAX.
Cardboard box M	590×277×115×4t	100pcs MAX.	5,000 MAX.
Cardboard box 1/2L	613×298×298×7t	200pcs MAX.	10,000 MAX.
Cardboard box L	613×298×518×7t	400pcs MAX.	20,000 MAX.

NICHIA CORPORATION	Model	NCxx0xxS	/
	Title	PACKING	
	No.	050111536511	